



## Tree Survey and Arboricultural Method Statement for Park Farm Cottage Stubton

4<sup>th</sup> May 2023

Revised 25<sup>th</sup> October 2023



## Contents

Contents.....	2
Introduction .....	3
Considerations .....	4
Damage to Trees <sup>2</sup> .....	4
Protection of trees during construction .....	6
Trees subject to Statutory Control .....	6
Trees and Wildlife .....	6
Implementation of Tree Works.....	6
Design considerations .....	6
Arboricultural constraints related to BS5837 grading.....	7
Tree Survey .....	9
Methodology & limitations.....	9
Site description .....	9
Recorded information .....	11
Tree Survey Plan.....	12
Survey Schedule .....	13
BS 5837:2012 Cascade chart for tree quality assessment.....	15
Arboricultural Impact Assessment (AIA).....	16
Impact of the development on the trees .....	16
Impact of the trees on the development .....	17
Arboricultural Method Statement (AMS) .....	17
Pre-development tree work .....	17
Construction exclusion zones .....	17
Removal of existing buildings .....	19
Foundation construction .....	19
Routing of services .....	19
Hard surfacing.....	20
Other measures .....	20
Sequence of works .....	20
Monitoring.....	20
Appendix A – Glossary of arboricultural terms.....	22
Appendix B – Site guidance notes .....	25
Appendix C – Bibliography & References .....	26

## Introduction

AT2 was instructed by Player Roberts Bell Architects to prepare a tree report with reference to the plans to replace the existing dwelling with three new dwellings at Park Farm Cottage in Stubton. This report describes the methods to be deployed to ensure minimum impact to the retained trees.

All rights in this report are reserved. The content and format are for the exclusive use of the entity purchasing the report and only the purchaser can rely on the report.

The report includes the following sections:

- Context of the report including the following considerations:
  - Tree physiology and potential for damage
  - The importance of protecting trees during construction
  - Trees subject to statutory controls
  - Trees and wildlife
  - Implementation of tree works
  - Design considerations
- Tree survey – provides an objective catalogue of the species, size and condition of the trees on or adjacent to a site. The results of the tree survey inform the design options.
- Arboricultural impact assessment – identifies and evaluates the direct and indirect impacts on existing trees that may arise as a result of the implementation of the design proposal.
- Arboricultural method statement – details of methodologies to be implemented in order to protect the retained trees through each stage of the development.
- Appendices
  - A. Glossary of arboricultural terms
  - B. Site guidance notes
  - C. Bibliography & references

Arboricultural terms that are included in the glossary in [appendix B](#) will be appear in **bold** on the first occasion of their use.



## Considerations

### Damage to Trees<sup>2</sup>

Trees that have good health and stability are well adapted to their surroundings. Any development activity which affects the adaptation of trees to a site could be detrimental to their health, future growth and safety. Tree species differ in their ability to tolerate change but all tend to become less tolerant after they have reached maturity or suffered previous damage or stress. Planning and subsequent site management should aim to minimise the effect of change.

The part of a tree most susceptible to damage is the root system, which, because it is not immediately visible, is frequently ignored. Damage to, or death of the root system affects the health, growth, life expectancy and safety of the entire tree. The effects of such damage may only become evident several years later. Damage may be the result of a number of insignificant but compounding factors that accumulate over time.

Damage to the stem and branches of a tree is not usually sufficient to kill the tree directly but may make it unsafe by affecting the weight of distribution of the crown or by facilitating decay in the long term. Such damage may also be disfiguring.

Roots perform several functions:

- Anchoring the tree in the ground
- Taking up water and minerals from the soil
- Storing food for times of dormancy

A tree typically has 80-90% of its roots within 60cm of the surface of the ground. Although they may be deeper within the dense mass of roots and soil close to the base of the tree it is rare for roots to penetrate to a depth greater than 2 metres.

Within a short distance of the stem the roots are highly branched so as to form a network of small-diameter woody roots that typically extend radially for a distance much greater than the height of the tree, except where impeded by unfavourable conditions. All parts of this system bear a mass of fine, non-woody absorptive roots.

The root system does not generally show the symmetry seen in the branch system. The development of all roots is influenced by the availability of water, nutrients, oxygen and soil penetrability. As far as these conditions allow, the root system tends to develop sufficient volume and area to provide physical stability.

The uptake of water and mineral nutrients by the root system takes place via the fine roots, typically less than 0.5 mm diameter. Their survival and functioning - which are essential for the health of the tree as a whole - depend on the maintenance of favourable soil conditions. The fine roots are short-lived with the majority dying each winter and with fresh ones developing in response to the needs of the tree.

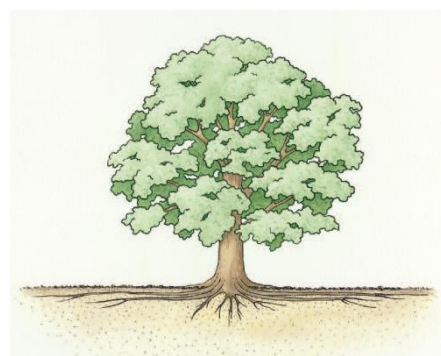

**Trees have relatively shallow but wide spreading roots<sup>4</sup>.**



# AT2 Tree Surveys

All parts of the root system, but especially the fine roots, are vulnerable to damage. Once roots are damaged, water and nutrient uptake is restricted until new ones have grown. Mature and over-mature trees respond slowly, if at all, to damage of their woody roots.

The main risks to tree roots come from physical damage and compaction to the surrounding soil.

- Physical damage:

During construction damage is often sustained when digging foundations or trenches for services. Surface roots are at risk when laying driveways, hardstanding and landscaping. Damaged roots are an entry point for infection and if a root is cut completely the tree loses a proportion of its capacity to take up water and minerals, store energy for the winter and weakens its anchorage in the ground.



**Walnut roots smashed by an excavator.**

- Compaction:

This is often caused by vehicular traffic. Tree roots need oxygen to respire and growth is inhibited or stopped when the airspaces in the soil are lost through compaction.

- Other damage:

Trees can also be damaged by contamination from fuel and chemical spillages or by fires.

Unless the damage is extremely severe it is unlikely that a tree will show symptoms immediately. More typically there is a steady decline over a few years with smaller leaves, crown dieback and possibly, eventual failure.

## Protection of trees during construction

*BS5837: 2012 Trees in relation to design, demolition and construction - Recommendations<sup>2</sup>* gives guidance on the implementation of protection for trees and roots before and during construction.

Recognising the importance of root health, the British Standard defines the **root protection area (RPA)** as:

*the minimum area around a tree deemed to contain sufficient roots and rooting volume to maintain the tree's viability, and where the protection of the roots and soil structure is treated as a priority.*

The RPA is calculated as an area equivalent to a circle with a radius 12 times the stem diameter measured at a height of 1.5m above ground level. Any modifications to the shape of the RPA should only be made based on a sound arboricultural assessment of likely root distribution.

The tree survey schedule on page 13 gives the radius of the RPA for each tree. This is the minimum distance at which barriers should be stationed to protect trees and their roots to form a **construction exclusion zone (CEZ)**.

## Trees subject to Statutory Control

Local Planning Authorities may assess trees as beneficial to the wider community in terms of their amenity value. They may protect such trees with a Tree Preservation Order (TPO). Work may still be permitted on protected trees but permission for the works must first be obtained from the LPA.

Some areas are designated conservation areas. Before carrying out works on a tree in a conservation area notice must be given to the LPA. The LPA can either allow the works to proceed or impose a TPO.

Where felling would produce more than five cubic metres of timber a felling license may be required from the Forestry Commission. However, this does not apply to trees growing in an orchard, garden, churchyard or public open space.

## Trees and Wildlife

Trees are hosts to nesting birds and mammals. Under the Wildlife and Countryside Act it is an offence to disturb any nesting bird or bat. Before carrying out any works it is important to ensure that there are no birds or bats in residence.

## Implementation of Tree Works

Tree work is skilled and potentially dangerous. Work should be carried out by trained and certificated contractors working to BS 3998: 2010 *Recommendations for Tree work<sup>1</sup>*.



## Design considerations

The relationship of buildings to large trees can cause apprehension to occupiers or users of nearby buildings or spaces, resulting in pressure for the removal of the trees. Buildings and other structures should be designed and/or sited with due consideration given to the trees' ultimate height and canopy spread. The design should take into account future growth so as to reduce the need for frequent remedial pruning or other maintenance.

Shading and light penetration should also be considered when positioning windows and indoor and outdoor living spaces to allow sufficient natural light. This survey does not include any shade

assessment although it is possible to model the shade cast by tree canopies at different times of the day and year.

Within the RPA, new hard surfacing should be gas and water permeable and should not require excavation into the soil (“**no-dig**”). BS5837 recommends that new hard surfacing should not exceed 20% of any existing unsurfaced ground within the RPA.

Early consultation and collaboration regarding the planning of utility runs is recommended so that underground services can be combined in a single trench that avoids the RPA.

To fulfil their potential, trees need to reach maturity. Many newly planted trees fail to survive the first two years due to inadequate ground preparation and lack of aftercare. In some studies, after 22 years only 42% had survived, putting long-term canopy cover and ecological service targets at risk.

Environmental legislation is evolving. The Environment Act 2021 and the forthcoming Town and Country Planning Act set targets for biodiversity net gain whilst the NPPF (National Planning Policy Framework) sets the objective of sustainable development including:

- Existing trees are retained wherever possible (paragraph 131)
- New streets are tree-lined, opportunities are taken to incorporate trees elsewhere in developments and that appropriate measures are in place to secure the long-term maintenance of newly-planted trees (paragraph 131)
- Opportunities to improve biodiversity in and around developments should be integrated as part of their design. (paragraph 180.d)

Over the long-term, larger, long-lived trees have lower annual maintenance costs and give much greater benefit. Where practical, landscape design should diverge from the limited palette of rowan and crabapple and consider varieties of larger species. A diverse mix of planting will help provide resilience against future pests and diseases. Guidelines recommended that the mix contains no more than 30% from the same family, 20% from the same genus and 10% of the same species.

The [Trees & Design Action Group](#) publishes a number of free guides designed to facilitate a better understanding of the range of returns trees offer new developments and how to secure these returns.

## Arboricultural constraints related to BS5837 grading

The survey schedule on page 13 includes a tree quality assessment grading in accordance with BS5837. Trees are graded as A, B, C or U in accordance with the assessment cascade chart on page 15.

- Trees identified as category A are those of high quality with an estimated remaining life expectancy of at least 40 years. These trees are particularly good examples of their species or of particular visual importance as arboricultural and/or landscape features. They pose a significant constraint to development and should be retained, protected and incorporated within the design where possible. Category A trees are shaded green on the tree plan.



**Fastigate oaks and planes on a Dutch street.**



# AT2 Tree Surveys

- Trees identified as category B are those of moderate quality with an estimated remaining life expectancy of at least 20 years. These are trees that might be included in category A, but are downgraded because of impaired condition (e.g. presence of significant though remediable defects, including unsympathetic past management and storm damage). They also pose a significant constraint to development and should be retained, protected and incorporated within the design where possible. Category B trees are shaded blue on the tree plan.
- Trees identified as category C are those of low quality with an estimated remaining life expectancy of at least 10 years. These are unremarkable trees offering low or only temporary/transient landscape benefits. They are in an adequate condition to be retained but could be replaced by new planting. Category C includes young trees with a stem diameter below 150mm which are not yet of a size to make a significant contribution to the landscape. These trees should not be considered to pose a significant constraint to development but should be retained and protected where possible. Category C trees are shaded grey on the tree plan.
- Trees identified as category U are those in such a condition that they cannot realistically be retained as living trees in the context of the current land use for longer than 10 years. This includes trees that have a serious structural defect, trees that are dead or are showing signs of significant overall decline and very low-quality trees suppressing adjacent trees of better quality. These trees are unsuitable for retention and should not be a constraint to development. Category U trees are shaded red on the tree plan.





## Tree Survey

### Methodology & limitations

The trees were inspected from ground level to produce a catalogue of species, size and general condition and their longer-term value. The soil was not examined and no samples were taken for analysis. There has been no attempt to assess potential root damage or subsidence potential.

The content of the tree survey should be used to inform the design options. It is not intended to be used as a detailed tree risk management survey. Trees are living organisms whose health and condition can change rapidly and no guarantee can be given as to the absolute safety or otherwise of any tree. The report may include some recommendations to reduce the likelihood of tree failure but absolute safety is not a realistic goal; even apparently sound trees can fail, particularly during extreme weather – best practice recommends that trees are inspected every 18 months when they are alternately in and out of leaf<sup>3</sup>.

The position of the trees on the plan on page 12 is not intended to infer ownership which should be clarified before any tree work is carried out.

### Site description



**Park Farm Cottage looking west from Fenton Road.**

The detached property is set back from Fenton Road and surrounded by lawned gardens with a selection of ornamental trees. The local planning authority's website shows that the property is not within a conservation area and there are no tree preservation orders. A tree plan is included on page 12 showing canopies shaded in accordance with their BS5837 categories and their root protection areas coloured magenta. At the time of the visit the weather was fine and sunny.

# AT2 Tree Surveys



**The garden looking northwest.**

## Recorded information

The following details were recorded for each tree and tabulated in the survey schedule:

- Tree plan ID; G prefix denotes group of trees.
- Species; Common name and *botanical name*.
- Height in metres measured using a Nikon 550 Forestry Pro hypsometer.
- Girth and diameter measured at 1.5 metres above ground level (# denotes estimated measurement where trunk is inaccessible; typ. ⇒ typical value).
- Whether the tree has a single or multiple stems.
- The calculated radius in metres for the **root protection area** (shown in magenta in the tree survey plan on page 12).
- The cardinal spread of the crown in metres.
- Canopy height in metres (ground clearance).
- The height in metres to the crown break (height of the lowest branches on the main trunk).
- The life stage:
  - Young: establishing, usually with good vitality but as yet of limited significance in the landscape.
  - Semi-mature: established, normally vigorous, increasing in height and of increasing landscape significance.
  - Early-mature: established; approaching mature height with crown spreading.
  - Mature: fully established trees around the middle of their typical life expectancy; generally retaining good vitality and achieving full height but their crowns still spreading.
  - Over-mature: fully established trees toward the end of their typical life expectancy with declining vitality.
  - Ancient: surviving beyond the typical age range for the species. Very old with low vitality and liable to decline. May include important Veteran Trees.
- Physiological and structural condition including the presence of physical defects and decay.
- Estimated remaining contribution in years.
- Tree quality assessment grading in accordance with BS5837:2012 (see page 15).

For expediency some trees may have less detail recorded and, in some cases, similar trees may be grouped for the purposes of this survey.



## Tree Survey Plan



Shaded outline shows tree canopy graded in accordance with BS5837; RPA shown in magenta. The position of the trees is not intended to infer ownership which should be clarified before any tree work is carried out. This tree plan is also supplied as an AutoCAD dwg file, XREFerenced to the topographical model. The tree geometry including the canopy and RPA are stored as layers that can be easily imported and overlaid onto a design layout to produce a tree constraints plan. Note: the CAD drawing units are metres.



# Tree Survey Schedule

# AT2 Tree Surveys

Plan ID	Species	Height (m)	Girth (cm)	Diameter (m)	No. of Stems	RPA radius (m) (Area m <sup>2</sup> )	Spread (m)	Canopy height (m)	1st sig. branch hght/dir	Life stage Physiol. cond. Structural cond.	Observations, notes & recommendations	Remaining contribution (years)	BS5837 Grading
T1	Norway spruce <i>Picea abies</i>	11	82	0.26	1	3.1 (31)	N 4 E 4 S 3.5 W 3	1.5	2.5	Early-mature Good Good		10+	C2
T2	Apple <i>Malus domestica</i>	8	142	0.45	1	5.4 (92)	N 5.5 E 6 S 4.5 W 6	1.5	1.5	Mature Good Good		20+	B2
T3	Monkey puzzle <i>Araucaria araucana</i>	605	73	0.23	1	2.8 (24)	N 2.5 E 2.5 S 2.5 W 2.5	1	2	Semi-mature Good Good		10+	C2
T4	Flowering cherry <i>Prunus</i>	3	84	0.27	1	3.2 (32)	N 3.5 E 0.5 S 3.5 W 3	2	1.25	Mature Fair Poor		<10	U
G5	Flowering cherry <i>Prunus</i>	2	20 typ.	0.06	1	0.8 (2)	N 1.5 E 1.5 S 1.5 W 1.5	0.5	0.5	Young Good Good		10+	C2
G6	Mixed group	3	20 typ. 42 max.	0.06 0.13	1	0.8 (2)	N 1.5 E 1.5 S 1.5 W 1.5	0	0	Mature Good Fair	Lilac & holly	10+	C2
T7	Holly <i>Ilex aquifolium</i>	3	38 39	0.12 0.12	2	2.1 (14)	N 2 E 2 S 0.5 W 2	0	0	Early-mature Good Good		10+	C2
G8	Mixed group	4	30 typ.	0.10	1	1.1 (4)	N 2 E 2 S 2 W 2			Semi-mature Good Good	Cherries	10+	C2
G9	Mixed group	3	34 typ.	0.11	1	1.3 (5)	N 2 E 2 S 2 W 2	1.5	1	Semi-mature Good Good	Cherry, photinia, apple.	10+	C2

## Tree Survey Schedule

# AT2 Tree Surveys

Plan ID	Species	Height (m)	Girth (cm)	Diameter (m)	No. of Stems	RPA radius (m) (Area m <sup>2</sup> )	Spread (m)	Canopy height (m)	1st sig. branch hght/dir	Life stage Physiol. cond. Structural cond.	Observations, notes & recommendations	Remaining contribution (years)	BS5837 Grading
T10	Oak <i>Quercus robur</i>	16	300	0.95	1	11.5 (413)	N 8.5 E 9 S 7.5 W 7.5	2	2.5	Mature Good Good		40+	A2
T11	Weeping willow <i>Salix x chrysocoma</i>	14	188 #	0.60 #	1	7.2 (162)	N 5.5 E 4 S 9 W 10	2	2	Mature Good Good		20+	B2
T12	Silver birch <i>Betula pendula</i>	12	57 #	0.18 #	1	2.2 (15)	N 3 E 2 S 2 W 3	1.5	2	Early-mature Good Good		20+	B2

# BS 5837:2012 Cascade chart for tree quality assessment

Category and definition	Criteria (including subcategories where appropriate)	Identification on plan
<b>Trees unsuitable for retention</b> (see Note)		
<b>Category U</b> Those in such a condition that they cannot realistically be retained as living trees in the context of the current land use for longer than 10 years	<ul style="list-style-type: none"> <li>Trees that have a serious, irremediable, structural defect, such that their early loss is expected due to collapse, including those that will become unviable after removal of other category U trees (e.g. where, for whatever reason, the loss of companion shelter cannot be mitigated by pruning)</li> <li>Trees that are dead or are showing signs of significant, immediate, and irreversible overall decline</li> <li>Trees infected with pathogens of significance to the health and/or safety of other trees nearby, or very low-quality trees suppressing adjacent trees of better quality</li> </ul> <p><i>NOTE Category U trees can have existing or potential conservation value which it might be desirable to preserve</i></p>	Red
	<b>1 – Mainly arboricultural qualities</b>	<b>2 – Mainly landscape qualities</b>
		<b>3 – Mainly cultural values, including conservation</b>
<b>Trees to be considered for retention</b>		
<b>Category A</b> <b>Trees of high quality</b> with an estimated remaining life expectancy of at least 40 years	Trees that are particularly good examples of their species, especially if rare or unusual; or those that are essential components of groups or formal or semi-formal arboricultural features (e.g. the dominant and/or principal trees within an avenue)	Trees, groups or woodlands of particular visual importance as arboricultural and/or landscape features
<b>Category B</b> <b>Trees of moderate quality</b> with an estimated remaining life expectancy of at least 20 years	Trees that might be included in category A, but are downgraded because of impaired condition (e.g. presence of significant though remediable defects, including unsympathetic past management and storm damage), such that they are unlikely to be suitable for retention for beyond 40 years; or trees lacking the special quality necessary to merit the category A designation	Trees present in numbers, usually growing as groups or woodlands, such that they attract a higher collective rating than they might as individuals; or trees occurring as collectives but situated so as to make little visual contribution to the wider locality
<b>Category C</b> <b>Trees of low quality</b> with an estimated remaining life expectancy of at least 10 years, or young trees with a stem diameter below 150 mm	Unremarkable trees of very limited merit or such impaired condition that they do not qualify in higher categories	Trees present in groups or woodlands, but without this conferring on them significantly greater collective landscape value; and/or trees offering low or only temporary/transient landscape benefits
		Trees with no material conservation or other cultural value
		Grey

## Arboricultural Impact Assessment (AIA)

A tree survey schedule is included on page 13.

### Impact of the development on the trees

In order to accommodate the new dwellings, it will be necessary to remove T2 Apple, T3 Monkey puzzle, T4 Flowering cherry, one out the three young cherries in G5, T7 Holly and the mixed groups G6 and G9 as shown in the plan below.



**Trees to be removed shown with dashed outline. Root protection areas shown in magenta. Existing buildings with dark grey shading and proposed dwellings with light grey shading.**

On completion of construction the gardens will be replanted with a new tree landscaping scheme.

The footprint of the development is outside of the root protection area of the retained trees so there is no requirement for specially engineered foundations.

Whilst the proposed development will result in the loss of a number of trees, the better-quality trees will be retained and only lower-quality trees and those graded unsuitable for retention will be removed. The public view into the site will be largely unchanged so the impact will be minimal.

Measures to minimise damage to the retained trees are detailed in the arboricultural method statement below.



## Impact of the trees on the development

The design takes into account the size, position and future growth of the trees relative to the dwellings to minimise issues of shading, seasonal nuisance, frequent remedial pruning or future pressure for removal.

## Arboricultural Method Statement (AMS)

### Pre-development tree work

Prior to commencement of construction the trees identified in the [arboricultural impact assessment](#) will be removed (T2 Apple, T3 Monkey puzzle, T4 Flowering cherry, one out the three young cherries in G5, T7 Holly and the mixed groups G6 and G9). The tree contractor will carry out checks for nesting birds and bats. The disposal of timber, brash, stumps and other arisings will be agreed with the client. Where stumps are to be removed from within the RPA of retained trees they should be ground out using a stump grinder rather than pulled out with an excavator to avoid damaging the roots of the retained trees.

### Construction exclusion zones

Before any development commences, protective barriers will be installed to protect the trunks and lower limbs of the trees and to constrain construction traffic to the existing hard surfaces. The position for the barrier is shown in an A1 size 1:100 scaled tree protection plan "*Park Farm Cottage, Stubton AIA-A1 TPP.pdf*", a section of which is shown overleaf. Due to surveying limitations, discrepancies may exist in the relative position of features on the plan, therefore all measurements for RPAs should be taken directly from the trees themselves.

Examples of suitable protective barriers are shown below.

# AT2 Tree Surveys

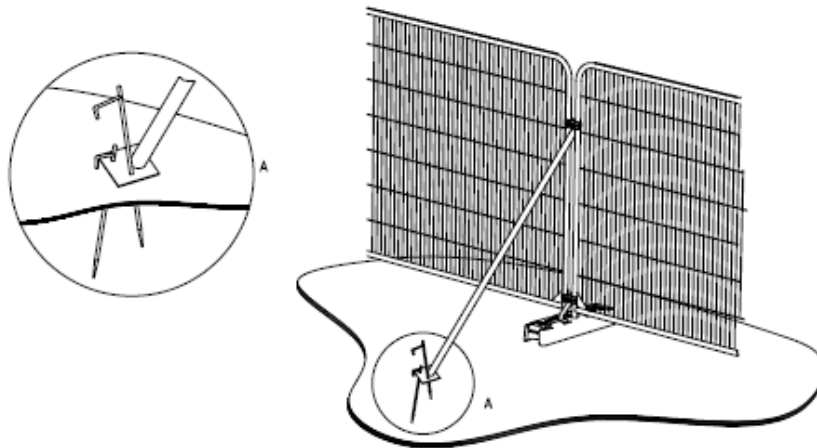

a) Stabilizer strut with base plate secured with ground pins

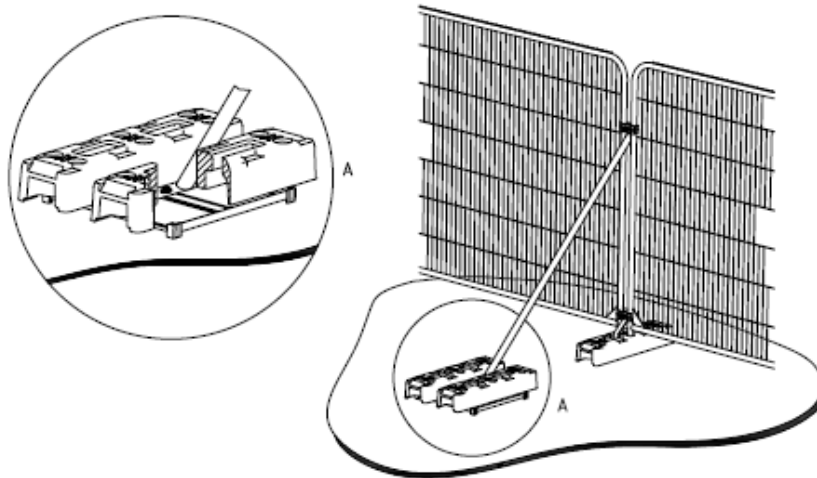

b) Stabilizer strut mounted on block tray

## Protective Barrier (British Standard 5837: 2012)

The barrier will have all-weather notices attached with words such as:

“CONSTRUCTION EXCLUSION ZONE – NO ACCESS”.

All barriers will remain in place until completion of all works.

# AT2 Tree Surveys



Extract from the tree protection plan showing siting of protective fencing.

## Removal of existing buildings

The existing buildings are all outside of the RPA of the retained trees so no special measures will be required over and above the protective fencing.

## Foundation construction

The new foundations will be outside of the RPA of the retained trees so special foundations will not be required and conventional strip foundations will be used.

## Routing of services

Early consultation and collaboration regarding the planning of utility runs is recommended so that underground services avoid the RPA.

Services will be connected to the existing service runs and any new services will be routed outside of the root protection area of the retained trees.

Further guidance can be found in the National Joint Utilities Group - Volume 4: *Guidelines for the Planning, Installation and Maintenance of Utility Apparatus in Proximity to Trees*<sup>9</sup>.

## Hard surfacing

No new hard surfacing is planned within the RPA of the retained trees.

## Other measures

- Due to the highly alkaline leachate produced during the curing of wet concrete, concrete will not be poured within the root protection area (RPA) unless an impermeable liner has been installed.
- To avoid contamination and compaction, no materials will be stored within 10 metres of a tree trunk or on any unprotected soil surfaces. This includes building materials, scaffolding, fuel, site huts and temporary toilets.
- No mixing or storage of materials will take place up a slope where they may leak down into an RPA. Where the contours of the site create a risk of harmful spillages running into RPAs, precautionary measures such as sandbags and heavy-duty plastic sheeting will be installed to prevent contamination.
- Notice boards will not be attached to any part of a tree and no fires will be allowed within 10 metres of the canopy or the protective barrier of any retained tree.
- If any fencing is to be installed within the RPA of any tree, the post holes must be carefully dug by hand and positioned so that no roots greater than 25mm in diameter are severed. As above, post-fixing concrete will not be used unless an impermeable liner has been installed.

## Sequence of works

- 1) [Pre-development tree work](#) to remove trees identified in the [Arboricultural Impact Assessment \(AIA\)](#).
- 2) Installation of protective fencing to establish [Construction exclusion zones](#).
- 3) Demolition of existing buildings.
- 4) Site development including [Routing of services](#) and installation of [Hard surfacing](#).
- 5) Removal of protective fencing.

## Monitoring

The main contractor will be responsible for:

- Monitoring of all operations with regard to tree protection on site.
- Maintaining the integrity of all tree protection measures.
- Keeping a copy of the tree protection plan on site for reference during construction and for the induction of staff and contractors.
- The compliance of sub-contractors.
- Ensuring that the planning conditions attached to the planning consent are adhered to at all times.



# AT2 Tree Surveys



## Appendix A – Glossary of arboricultural terms

**Access facilitation pruning** One-off tree pruning, without significant adverse impact on tree physiology or amenity value, which is directly necessary to provide access for operations on site.

**Arboricultural impact assessment (AIA)** Study to identify and evaluate the direct and indirect impacts on existing trees that may arise as a result of the implementation of a site layout proposal.

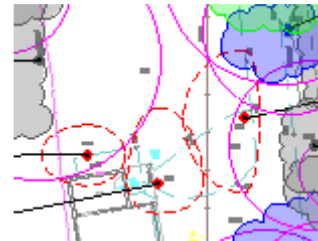

**Arboricultural method statement (AMS)** Details of methodologies to be implemented in order to protect the retained trees (**see also tree protection plan (TPP)**).

**Codominant stems** Codominant stems occur when a tree grows with two or more main stems or 'leaders' that are about the same diameter and emerge from the same location on the main trunk. The bark for each stem is trapped inside the fork preventing them from fusing together. This may also be referred to as a compression fork.



The presence of codominant stems with included bark reduces the strength of the union and therefore increases the risk of failure under loading during strong winds<sup>12</sup>.

However, the presence of included bark does not mean the tree will fail. Codominant stems are a common feature of many trees and most will live to the end of their natural life without a problem. The decision whether to take remedial action should take a range of factors into consideration including the size, position and condition of the tree and the proximity of 'targets' close to the tree.

**Construction exclusion zone (CEZ)** An area based on the **RPA** to be protected during development by the use of barriers and/or ground protection to ensure the long-term retention of a tree.

**Crown lifting** The removal of lower branches and/or parts of pendulous upper branches to provide clearance over roads and paths and allow more light under a tree or into nearby property.

Work specified as a clearance height above ground level.



# AT2 Tree Surveys

**Crown reduction** The cutting back of branches to reduce the overall size of a tree's canopy. Crown reduction should seek to retain the tree's natural form and a flowing branch line without leaving stumps.

Work specified as a reduction in height and radial width and/or annotated photographs.



**Drop crotch pruning** Removing a portion of a branch or stem by cutting back to a lateral branch which is at least 1/3 of the diameter of the section that is being removed.



**Epicormic growth** Bushy shoots growing directly from the trunk arising from adventitious or dormant buds.

**Formative pruning** Pruning of young trees to produce a good shape and prevent future management problems.

**Hanger** A broken branch lodged or hanging in the canopy.

**No-dig construction** With reference to foundations, hard surfacing and utilities, the design should not require excavation into the soil, including through lowering of levels and/or scraping, other than the removal, using hand tools or an air-spade, of any turf layer or other surface vegetation.

**Pile and beam foundation** Type of foundation where mini-piles or screw piles are bridged with concrete and/or steel beams and the floor suspended using block and beam construction with a vented void below. The underside of the beams is at or just above ground level. Often used where conventional strip foundations would cause unacceptable root damage.



**Pollarding and Coppicing** The removal of all or nearly all of a tree's branches and foliage. Pollarding is generally only appropriate on trees where the practice has been long established and carried out regularly such as willow, lime and plane.

A framework pollard removes all the smaller branches but leaves a framework of major limbs.

With coppicing trees or shrubs are cut close to ground level and allowed to regenerate.



# AT2 Tree Surveys

**Root protection area (RPA)** The minimum area around a tree deemed to contain sufficient roots and rooting volume to maintain the tree's viability, and where the protection of the roots and soil structure is treated as a priority (shown in magenta in the tree survey plan on page 12).

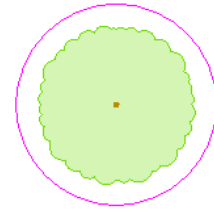

**Ruderals** A ruderal species is a plant species that is first to colonize disturbed lands such as construction sites.

**Sucker growth** Similar to epicormic growth but suckers shoot from the roots of the parent tree.

**Target pruning** Pruning to create or maintain clearance from buildings, street lights, guttering, aerials, etc.

**Topographical survey** An accurate depiction of an area of land which is scaled and detailed to show all the natural and manmade features and their levels.

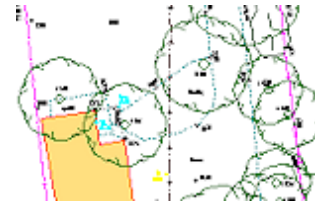

**Tree constraints plan (TCP)** Scale drawing showing the canopy and RPA of the trees overlaid onto the layout scheme to highlight potential conflict. The TCP may include shading modelling.



**Tree protection plan (TPP)** Scale drawing showing finalised layout, tree retention and tree protection measures detailed in the **arboricultural method statement (AMS)**.

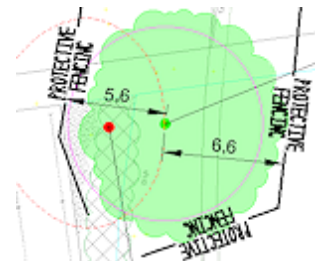

## Appendix B – Site guidance notes

Barrel Tree Consultancy has produced a series of site guidance notes that give more detail on specific elements of the management of trees on construction sites. They can be downloaded using this [link to their website](#) or by using the QR codes or links below.



### 1: Monitoring protection

<https://www.barrelltreecare.co.uk/resources/technical-guidance/sgn01/>



### 2: Fencing protected trees

<https://www.barrelltreecare.co.uk/resources/technical-guidance/sgn02/>



### 3: Ground protection

<https://www.barrelltreecare.co.uk/resources/technical-guidance/sgn03/>



### 4: Pollution control

<https://www.barrelltreecare.co.uk/resources/technical-guidance/sgn04/>



### 5: Site cranes and piling rigs

<https://www.barrelltreecare.co.uk/resources/technical-guidance/sgn05/>



### 6: Height restrictions

<https://www.barrelltreecare.co.uk/resources/technical-guidance/sgn06/>



### 7: Excavation in root protection areas

<https://www.barrelltreecare.co.uk/resources/technical-guidance/sgn07/>

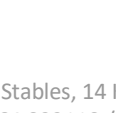

### 8: Removing surfacing and structures in root protection areas

<https://www.barrelltreecare.co.uk/resources/technical-guidance/sgn08/>



### 9: Installing/upgrading surfacing in root protection areas

<https://www.barrelltreecare.co.uk/resources/technical-guidance/sgn09/>



### 10: Installing structures in root protection areas

<https://www.barrelltreecare.co.uk/resources/technical-guidance/sgn10/>



### 11: Installing services in root protection areas

<https://www.barrelltreecare.co.uk/resources/technical-guidance/sgn11/>



### 12: Landscaping in root protection areas

<https://www.barrelltreecare.co.uk/resources/technical-guidance/sgn12/>



## Appendix C – Bibliography & References

- 1 British Standards Institution, (2010). *BS 3998: 2010 – Recommendations for tree work*. Milton Keynes: BSI
- 2 British Standards Institution, (2012). *BS 5837: 2012 – Trees in relation to design, demolition and construction – Recommendations*. Milton Keynes: BSI
- 3 Cavanagh v Witley Parish Council (1) and D Kevin Shepherd (t/a Shepherd Tree Surgeons & Forestry Contractors) (2) [2017]
- 4 Crow, P. (2005). *The Influence of Soils and Species on Tree Root Depth*, Forestry Commission Information Note, Forestry Commission, Edinburgh.
- 5 Guy Watson & Ted Green. *Fungi on Trees – An Arborists Field Guide* (2011) Arboricultural Association
- 6 Lonsdale, D. (2021). *Principles of Tree Hazard Assessment and Management*. Arboricultural Association.
- 7 Mattheck, C. & Breloer, H. (2006). *The Body Language of Trees, A Handbook for Failure Analysis*. The Stationery Office.
- 8 NHBC Standards Part 4 (2021). *Chapter 4.2 Building near trees*. National House Building Council.
- 9 NJUG Volume 4: *Guidelines for the Planning, Installation and Maintenance of Utility Apparatus in Proximity to Trees*, (Issue 2: 16<sup>th</sup> November 2007). National Joint Utility Group.
- 10 Rose, B. (2020). *The Use of Cellular Confinement Systems Near Trees: A Guide to Good Practice*. Guidance Note 12. Arboricultural Association.
- 11 Shigo, A. L. (1991). 3<sup>rd</sup> ed. *Modern Arboriculture*. Shigo & Trees, Associates.
- 12 Smiley, E. T. Does Included Bark Reduce the Strength of Codominant Stems?, *Journal of Arboriculture* 29(2), March 2003, pages 104-106
- 13 Strouts, R. G. & Winter, T. G. (2000). 2<sup>nd</sup> ed. *Diagnosis of Ill Health in Trees*. The Stationery Office.
- 14 John Roberts, Nick Jackson & Mark Smith (2006). *Tree Roots in the Built Environment*. Arboricultural Association.
- 15 Trees & Design Action Group (TDAG), (2021). *Trees, planning and Development – A Guide for Delivery*. <https://www.tdag.org.uk/>

